

UNIKA 400 VINTAGE GUN METAL



Kitchen Sinks

Code: N156 F86

UNIKA R15 B 400x400 À FLEUR VINTAGE GUNMETAL



DETAILS

Coloring Gun Metal

Edge/Installation Type Flush-mount | Top-mount

Finish PVD

Material AISI 304 stainless steel

Texture Vintage

Base 45 cm

Dimensions 440x440 mm

Standard fittings Fixing hooks, gasket, drain, overflow and siphon, boxed packing

Mixer holes No standard holes

Built-in hole [View technical data sheet](#)

Drainer No

Width 44 cm

Bowl dimension 400 x 400 mm

Number of bowls 1 bowl

Waste fitting 3,5" drain

FEATURES

Basket 3,5" waste fitting The drain is equipped with a large 3.5" drain, with the practical basket cap that prevents the discharge of solid parts.

Gun Metal The Gun Metal finish is obtained by treating steel with a physical process called PVD (Physical Vacuum Deposition) which deposits particles of noble metals on the surface. The result is a unique and refined aesthetic effect, and an improvement of the mechanical properties of the steel which is more resistant to impact and scratches.

High thickness 1mm thick steel. A significant thickness, which guarantees the maximum sturdiness and durability.

Perimetral overflow The overflow is always a security on the Foster sinks that prevents the overflow of water in case of oversights. The perimeter drain solution improves aesthetics thanks to its square and essential shape.

Small radius Bowls with squared shapes with a modern design and an increased capacity, for a minimal aesthetics connected with an extreme practicality.

VINTAGE PVD The prestigious PVD finish combines with the care for detail of the Vintage finish, to create a combination of unique elegance.

TECHNICAL DATA

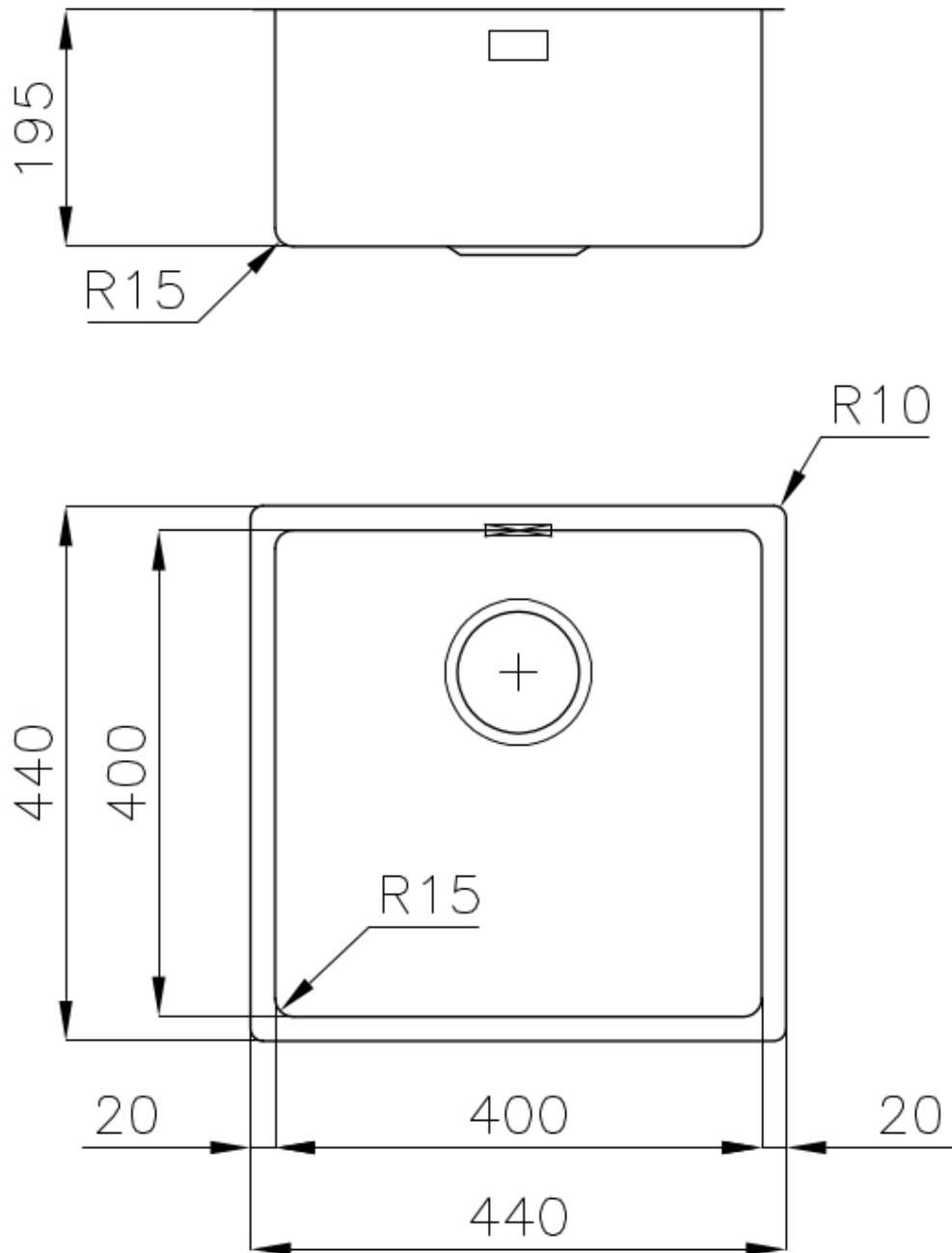

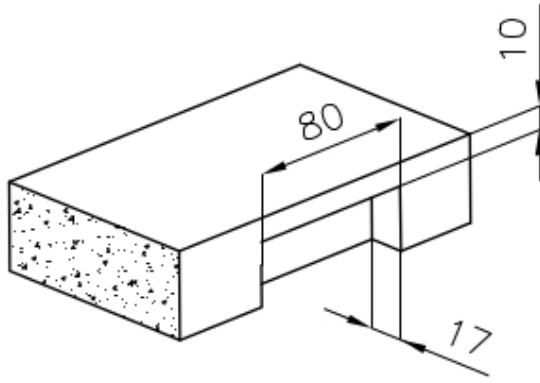

Intaglio per il troppo-pieno
Recess for housing the over-flow

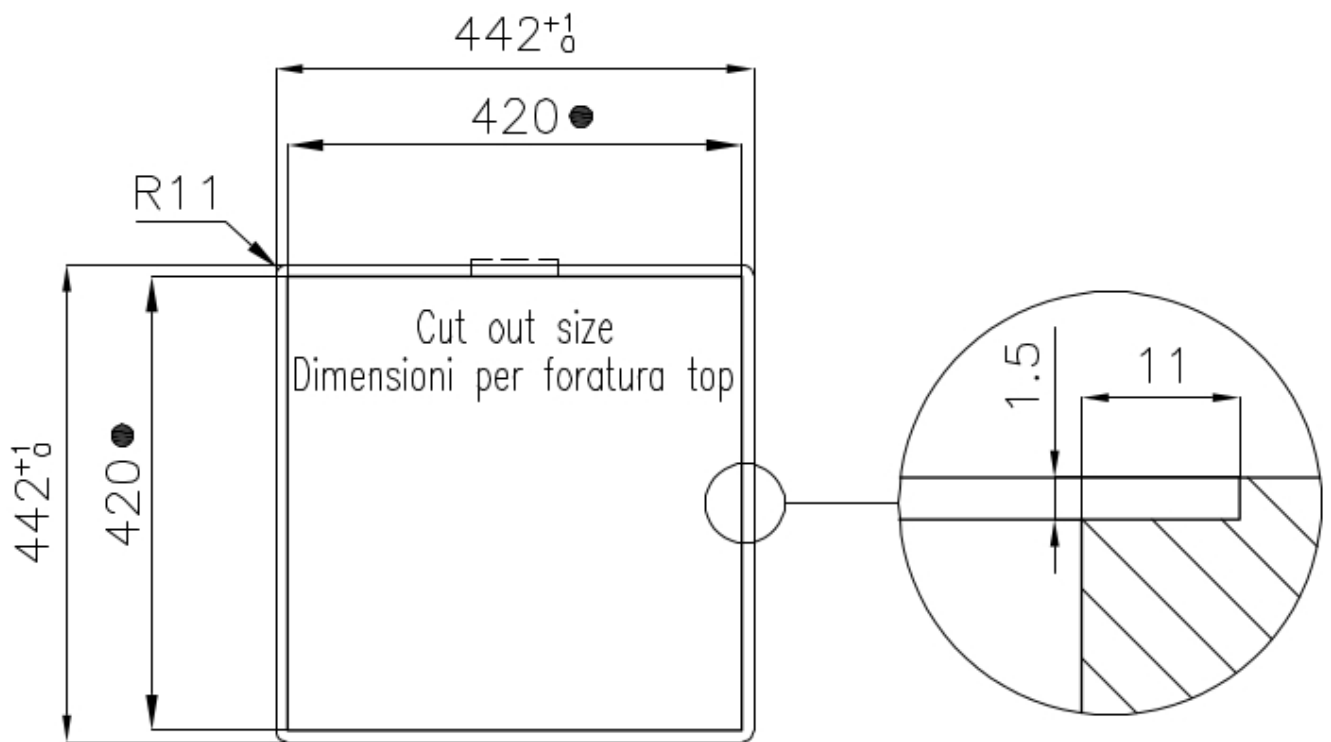

- Built-in cut out for FTS – Foratura per installazione FTS

GALLERY

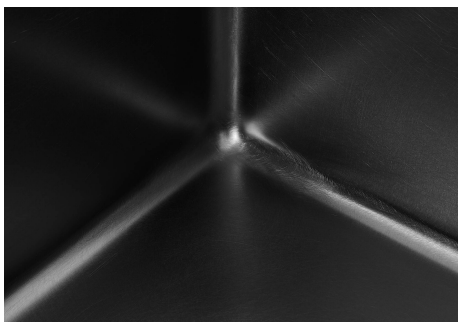

OPTIONAL ACCESSORIES



CUVETTE PERFOREE INOX

A154 F00

* only in combination with the accessory
A644 F04



CUVETTE PLASTIQUE BLANCHE

A153 A00

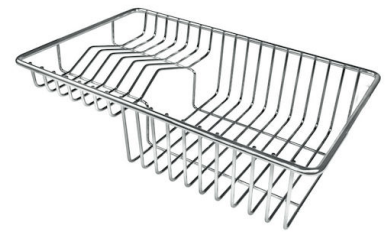

**GRILLE POR.ASSIETTES INOX
mm214x379**

A100 C03

* only in combination with the accessory
A644 A01

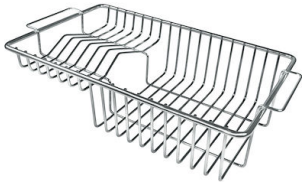

**GRILLE PORTE-ASSIETTES INOX
250x425**

A100 B01



**GRILLE PORTE-ASSIETTES INOX
25x35**

A100 A54

* only in combination with the accessory
A644 F04



**PLANCHE DE DECOUPE CRYSTAL
23x41 CM**

A631 C00



**PLANCHE DE DECOUPE DOUBLE
HDPE**

A644 A01



**PLANCHE DE DECOUPE DOUBLE
IROKO**

A644 F04



**PLANCHE DE DECOUPE HDPE
27x42 CM**

A657 F01



CUVETTE INOX PERFOREE

A151 F00

* only in combination with the accessory

A644 A01



KIT RÂPES ET PLANCHE DE DECOUPE HDPE

A159 A01

* only in combination with the accessory

A644 A01