

RIVA 750 GUN METAL

Kitchen Sinks

Code: N034 F56

RIVA BOWL 806x520 À FLEUR GUNMETAL



DETAILS

Coloring Gun Metal

Edge/Installation Type Flush-mount | Top-mount

Finish PVD

Material AISI 304 stainless steel

Texture Brushed in line

Base 80 cm

Dimensions 806 x 520 mm

Standard fittings Fixing hooks, gasket, drain, overflow and siphon, boxed packing

Mixer holes 2 standard holes - 3rd hole on request

Built-in hole

[View technical data sheet](#)

Drainer

No

Width

81 cm

Bowl dimension

750 x 374 mm

Number of bowls

1 bowl

Waste fitting

Drain with automatic control SPACE PUSH GUN METAL - PO

EQUIPMENT

2 x Black grid Milanello 8100
602
1 x Space Push
automatic waste fitting 8407
120

FEATURES

Gun Metal

The Gun Metal finish is obtained by treating steel with a physical process called PVD (Physical Vacuum Deposition) which deposits particles of noble metals on the surface. The result is a unique and refined aesthetic effect, and an improvement of the mechanical properties of the steel which is more resistant to impact and scratches.

ADDITIONAL HOLES
AVAILABLE

The sink can be customized with the execution on request of additional holes, usable for double-hole mixers, for remote controlled drains or for the installation of soap dispensers. The positions are marked on the drawings with dotted line holes.

Automatic waste fitting

The waste-fitting with round remote knob is supplied; a practical accessory which makes it unnecessary to get wet in order to drain the water from the bowl.

Diamond-shape bottom	The draining of water is an important feature in a sink, and it's always taken good care of in Foster products. In the bent-welded sinks, which would have a flat bottom, the proper draining is guaranteed by the elegant beveling, which helps the water flow.
Double mixer hole	The large tap counter is already fitted with a series of 2 tap holes. In the second hole it is possible to install the remote control of the automatic drain or, alternatively, a practical soap dispenser.
High thickness	1mm thick steel. A significant thickness, which guarantees the maximum sturdiness and durability.
Perimetral overflow	The overflow is always a security on the Foster sinks that prevents the overflow of water in case of oversights. The perimeter drain solution improves aesthetics thanks to its square and essential shape.
Save space system	Drain and siphon are designed to leave as much space as possible in the under-sink area, more and more useful today for theseparate waste collection systems.
Small radius	Bowls with squared shapes with a modern design and an increased capacity, for a minimal aesthetics connected with an extreme praticity.
Space waste fitting	The elegant SPACE steel cap closes the drain and leaves no visible residues collected in the basket below. Space also has a small footprint and allows the optimal use of the under-sink compartment.
Triple recess - sliding accessories	The Foster Milano sink has an ingenious design that makes it simple to use a large set of optional accessories. On the topmost supporting step, the innovative Black grids slide, creating a large and practical surface to rinse food and crockery. The second step is meant to support and allow the sliding of a complete combination of accessories, which make some operations practical and safe: rinse, drain, slice, grate... everything can be done inside the sink. The third supporting step is on the bottom of the bowl. On this step one can rest the Black grids, making it possible to rinse foodstuffs without their coming in contact with the bottom of the sink, which may be dirty.

TECHNICAL DATA

Lavello MILANELLO cod. 1034/05*

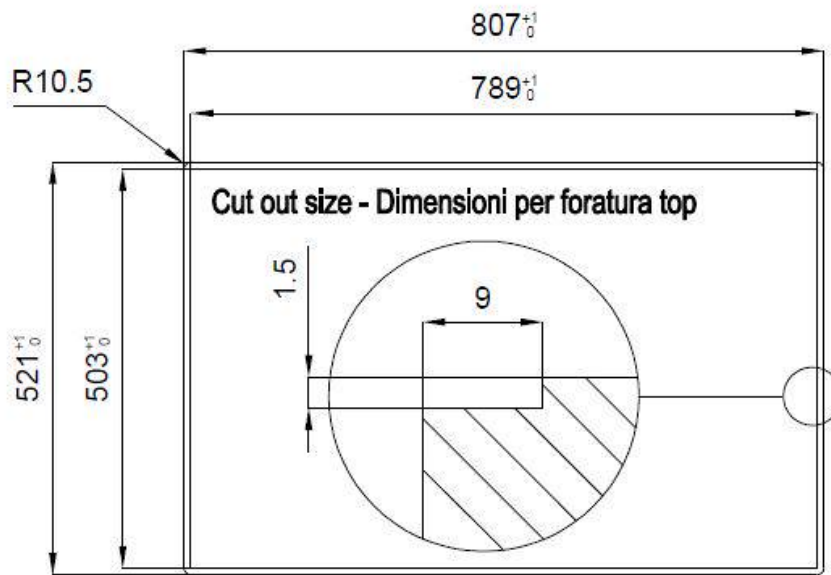

FT

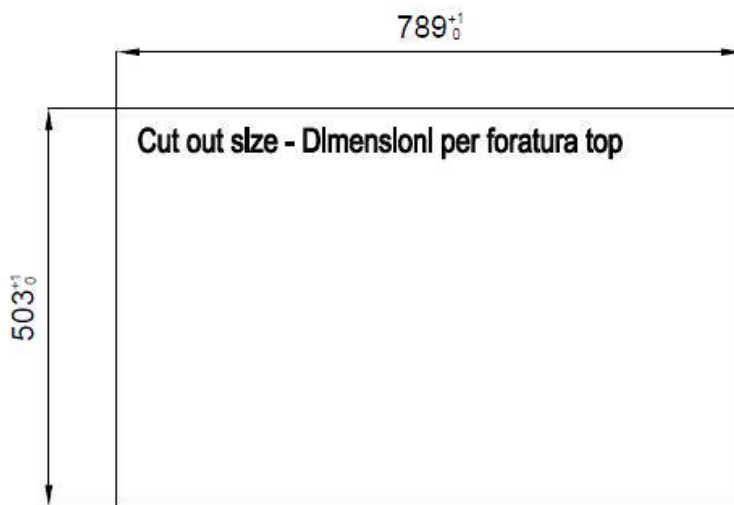

FTS

GALLERY

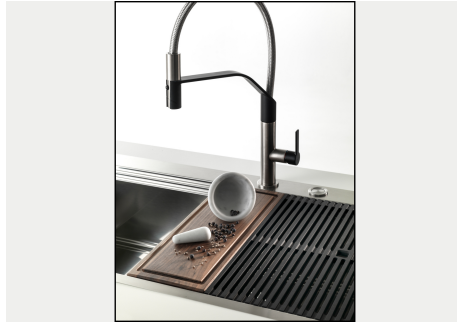

EQUIPMENT



GRILLE NOIRE POUR EVIERS RIVA
A100 E02



VIDAGE FADE PUSH GUN METAL
A407 A20

OPTIONAL ACCESSORIES



CUVETTE PERFOREE INOX

A154 F00

* only in combination with the accessory
A644 F04



**CUVETTE PERFOREE POUR EVIERS
RIVA**

A156 F00

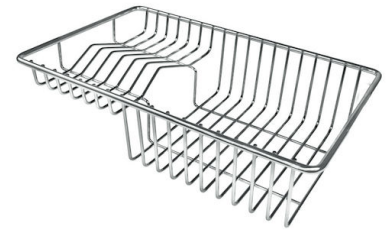

**GRILLE POR.ASSIETTES INOX
mm214x379**

A100 C03

* only in combination with the accessory
A644 A01



**GRILLE PORTE-ASSIETTES INOX
25x35**

A100 A54

* only in combination with the accessory
A644 F04



**PLANCHE DE DECOUPE DOUBLE
HDPE**

A644 A01



**PLANCHE DE DECOUPE DOUBLE
IROKO**

A644 F04



**PLANCHE DE DECOUPE HDPE
27x42 CM**

A657 F01



CUVETTE INOX PERFOREE

A151 F00

* only in combination with the accessory
A644 A01



**KIT RÂPES ET PLANCHE DE
DECOUPE HDPE**

A159 A01

* only in combination with the accessory
A644 A01

RECOMMENDED PAIRINGS



INCISO GUN METAL
R424 S56

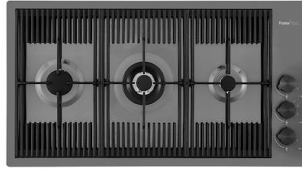

MILANO 3 BRULEURS GUN METAL
G680 F06

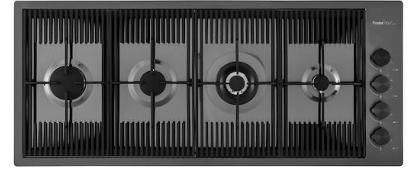

MILANO 4 BRULEURS GUN METAL
G681 F06



POLO
R525 A00