

VENTO INDUCTION (FR)

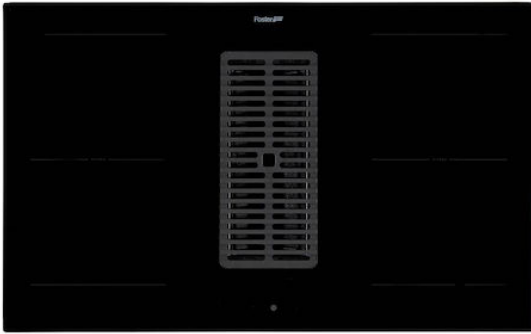

Induction Hobs

Code: I392 N46

TABLE CUISSON INDUCTION + ASPIRATION VENTO



DETAILS

Full description	Hoods Foster Milano heating element four zones, edge/installation type bevelled edge - for flush-mount (ft) or over-mount (fts) installation
Type	Induction Hob
Operation	Suction hood (filtering mode with optional carbon filters)
Material	Ceramic glass
Coloring	Black
Energy class	A+
Heating element	Four zones
Supply	230 - 380 V (50/60 Hz)
Total power	7.400 W**

Cooking zones	210 x 190 mm - 2.100 (3.000)* W
2 extended Bridge areas	3.700 W
Pressure	610 Pa
Air flow rate	650 mc/h
Noise level	49 - 70 dB(A)
Power settings	9 power settings per zone + Powerboost
Suction speed	10 suction speeds (9 + 1 intensive)
Width	82 cm
Dimensions	820 x 520 cm
Built-in hole	View technical data sheet
Grid	Aluminum Black
Type of commands	Touch Control
Safety	Safety equipment
Notes:	**With the PowerControl function, the maximum power can be set in users from 2,400 to 7,400 W in 100 W steps *PowerBoost

Notes: 2 washable grease filters;
Automatic delayed shutdown;
Grease and carbon filter saturation warnings;
Optional filtering operation with carbon filters.

FEATURES

Go&stop function	This device initially turns on the plates at maximum power until the selected temperature has been reached.
Powerboost	Booster function provides increased power to the selected plate. In particular, when the Booster is activated, the plate works for ten minutes at a very high power that allows to heat quickly large quantities of water.
Pot detector	All induction cooker hobs detect the pot resting on them, but they also calculate the area they cover. This system allows the energy to be used even more efficiently. Moreover, the plates switch off automatically when the pot is removed.
Smart fan system	Correct ventilation is essential for the induction hob to function in the best possible way. The Foster system automatically regulates the amount of ventilation to suit the temperatures reached.
Safe cooking	All Foster cooker hobs are equipped with safety valves. They shut off the gas supply very quickly if the flame accidentally goes out.
End-of-cooking programming	All operations are programmed by means of the touch-control on the glass itself. Each cooking plate is capable of independent programming, and thus the possibility to set different cooking times.
Timer	Independent timer from the end-of-cooking function.
Power control function	PowerControl function allows the use of induction technology also in case of household maximum power as low as 3 kW. The maximum power can indeed be self-limited to the desired level to a minimum of 2.8 kW. Once the maximum power is set, we can forget about the absorbed energy because Foster induction hob will give us a warning about possible limitations, allowing to choose how to allocate the available energy. The hob can be easily reprogrammed at any time to modify or remove the power limit.

Bridge zone

The new cooktops with Bridge function allow to associate two zones forming a single extended cooking zone for pots of large size, or for more than one cooking simultaneously, with maximum flexibility in pot positioning. With the additional Double Booster feature provided by all Bridge cooktops, the exceptional 3700 W power can be concentrated on a single plate or made available uniformly over the enlarged area.

TECHNICAL DATA

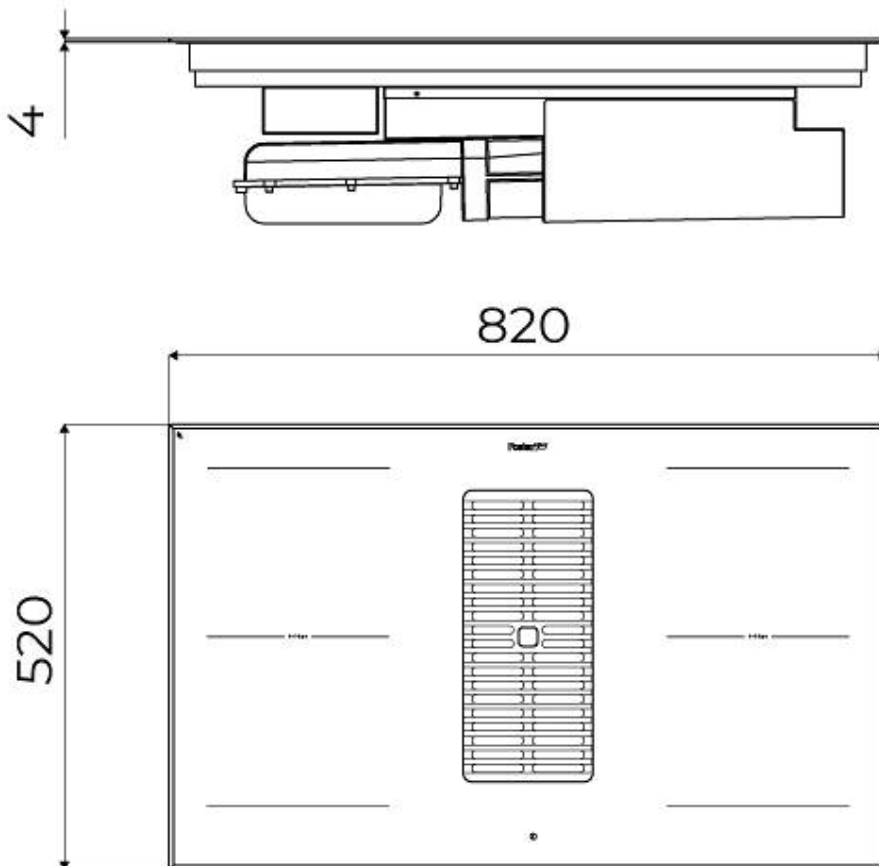

9700 577 - KIT H6 cm

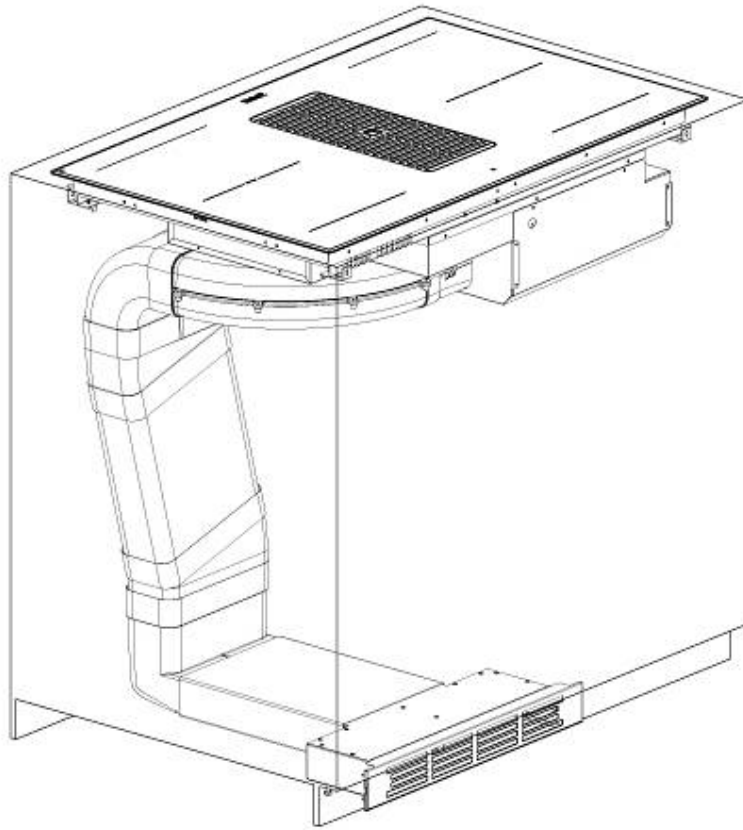

9700 580 - KIT H10 cm

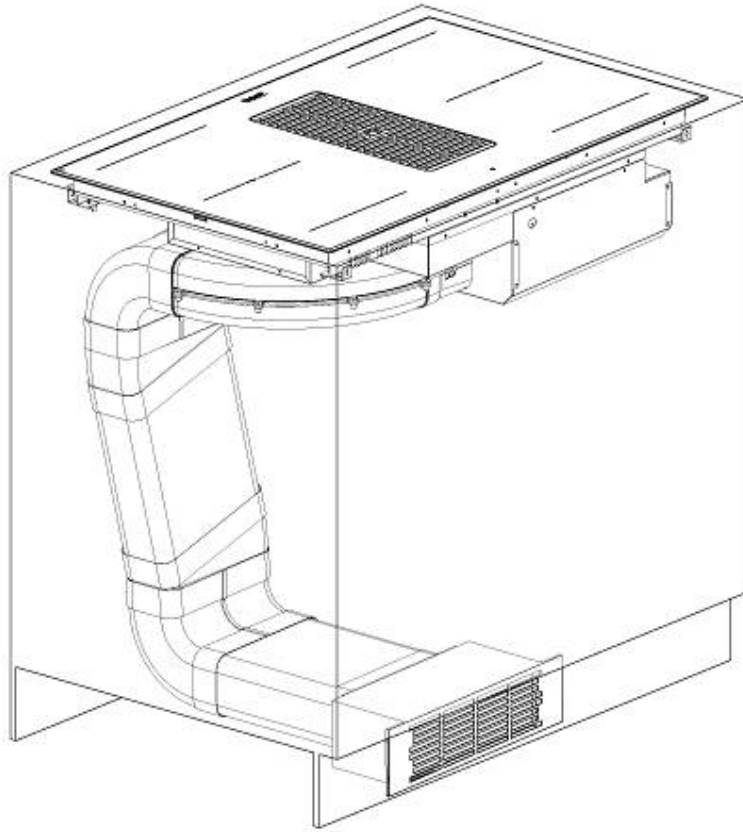

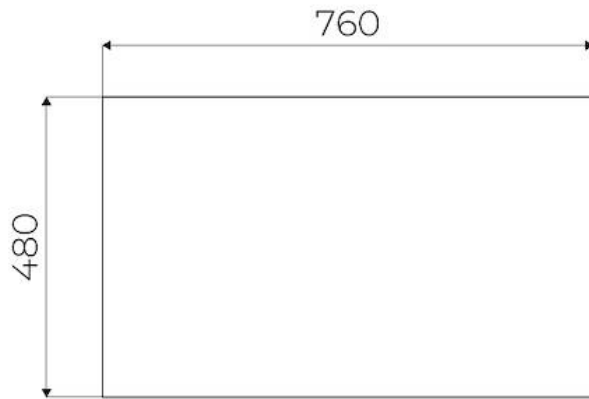

FTS - cut out

FT - cut out

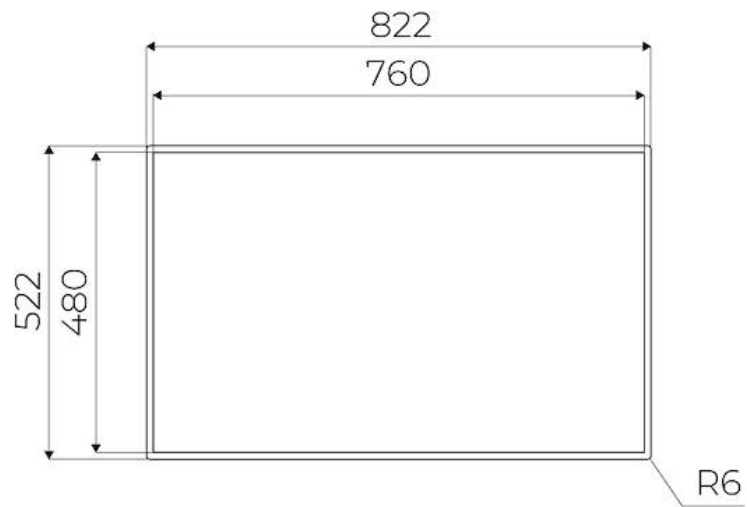

GALLERY

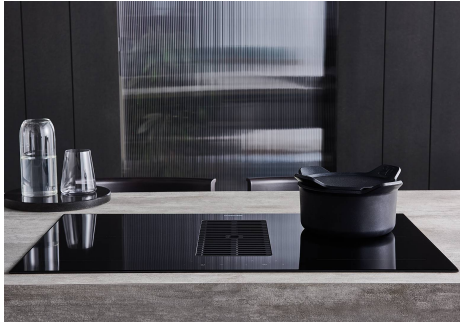

OPTIONAL ACCESSORIES



GRILLE VENTO
A803 F00



GRILLE VENTO COPPER
A803 A18



GRILLE VENTO GOLD
A803 A19



GRILLE VENTO GUN METAL
A803 A16

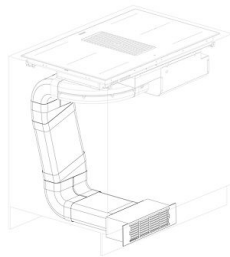

KIT FILTRE VENTO
A700 D80

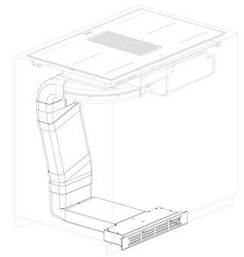

KIT FILTRE VENTO
A700 D77